



# BX150 Gas Detector



- Detects carbon monoxide, natural gas and LPG
- Single zone
- Catalytic and electrochemical sensors
- Audible alarm
- 230V and 12V DC
- Sensor fault relay output
- Panel mounting
- 96 x 48mm DIN enclosure
- Manual test function
- Self diagnostic
- 1 year guarantee

## Application

Duomo is recognised in the gas industry for providing a comprehensive range of low cost, high reliability gas detection systems for many applications. We have installed and commissioned natural gas and carbon monoxide sensors in boiler rooms, kitchens, car parks, aircraft hangers, factories and shopping centres.

The BX150 has been designed to meet all European Normative proposals for natural gas, LPG and carbon monoxide gas detectors.

## Operation

If the remote sensors sense the presence of gas the detector operates a pre-alarm relay. If the level continues to rise the main alarm relay is activated. For natural gas, the electrical supply to the safety shut off valve is broken. For carbon monoxide, a general alarm is sounded to allow evacuation of the area. Should a fault arise with the sensor or electrical connections to the sensor, a separate volt free relay is activated.

The pre-alarm is fixed for natural gas and LPG at 13% of the lower explosive level (LEL). For carbon monoxide it is fixed at 200ppm.

The main alarm threshold is fixed at 20% LEL for natural gas and LPG and 300ppm for carbon monoxide. This detector can be set for either carbon monoxide or natural gas and LPG.

A 'TEST' button checks the complete function of the BX150 and its sensor. A permanent diagnostic check is made of sensor function. If any sensors should become faulty or be connected incorrectly the 'FAULT' light will illuminate and the unit will fail safe.



### CAUTION!

Carefully read the following instructions prior to installation of this device. Always keep this pamphlet for future reference. Ensure that the gas detection system is wired correctly and is only used for the purpose for which it is intended.

# Overall Dimensions

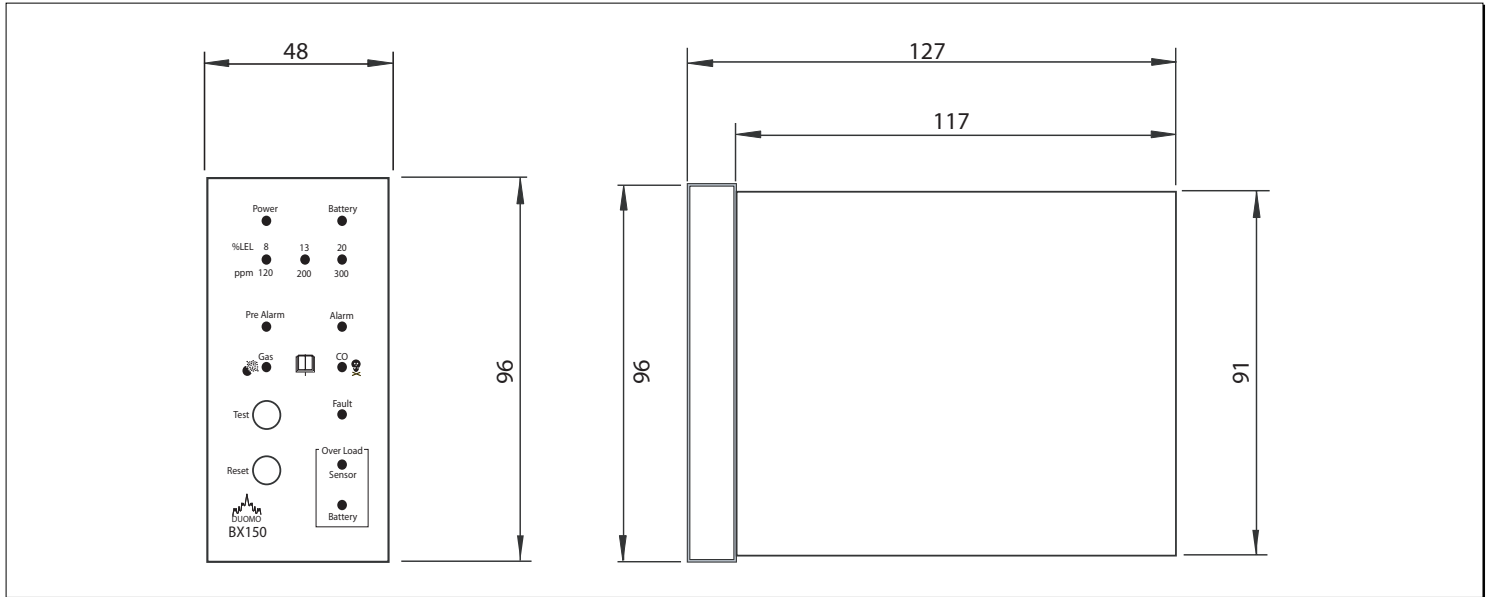

# BX150 Fascia

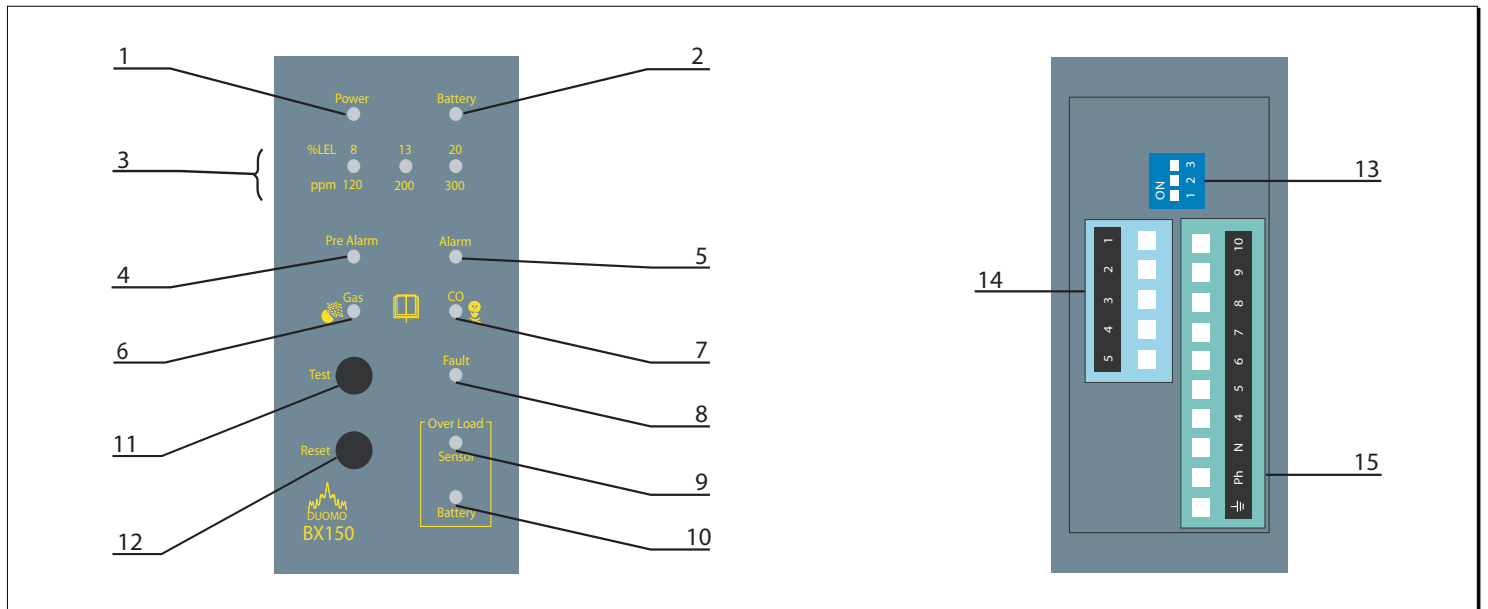

# Key

- 1. Power On** - Lights when supply voltage is applied. This light flashes during self diagnostics start up.
- 2. Battery** - This lights when the BX150 is being powered by the standby battery. When this light flashes the standby battery has low charge.
- 3. Gas Level Indicators** - Displays current level of gas detected\*.
- 4. Pre-alarm LED** - These lights indicate the level of gas sensed. 8 - 13 - 20% LEL and 120 - 200 - 300ppm.
- 5. Main Alarm** - 20% LEL concentration of gas detected. Main alarm relay actuated.
- 6. Explosive** - This lights when the internal DIP switch for explosive gas is moved to the gas position.
- 7. Toxic Gas** - This lights when the internal DIP switch for carbon monoxide is moved to the carbon monoxide position.
- 8. Fault** - Indicates a short circuit, sensor fault, loss of signal or incorrect connection of the sensor.
- 9. Over Load Sensor** - Short circuit or high current absorption in the sensors.
- 10. Over Load Battery** - Battery not connected properly or anomalous voltage consumption.
- 11. Test** - When pressed checks the sequence and function of the BX150.
- 12. Reset** - Press this to reset the detector after an alarm or sensor fault condition.
- 13. Switches** - These are used to turn the sensor on/off, determine the type of gas to be sensed, to turn the intrinsically safe option on and off and alter the alarm actuation.
- 14. Signal Terminal Block** - Sensor terminals.
- 15. Power Terminal Block** - Power terminals.

# Typical Wiring Schematic for BX150

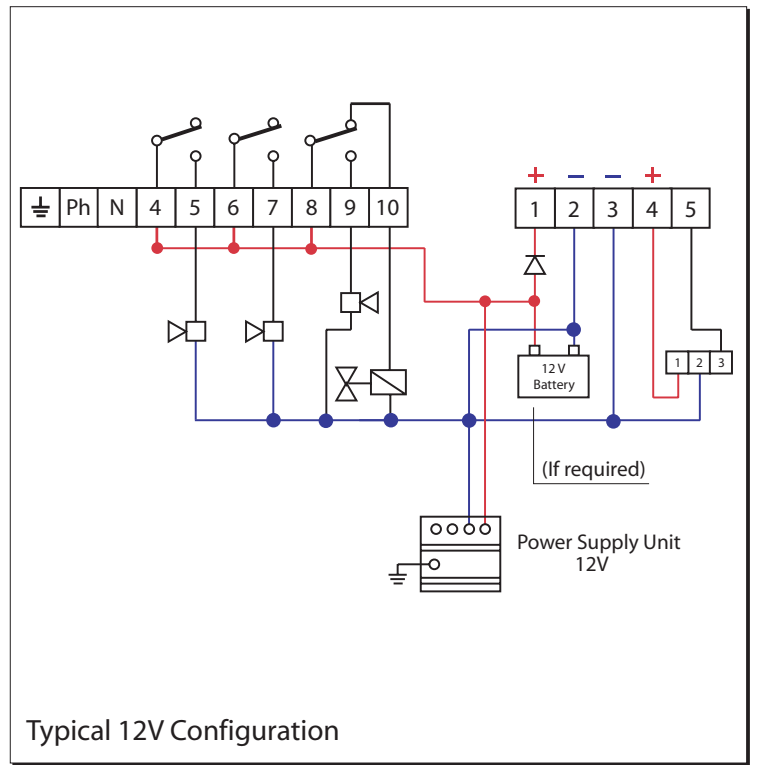
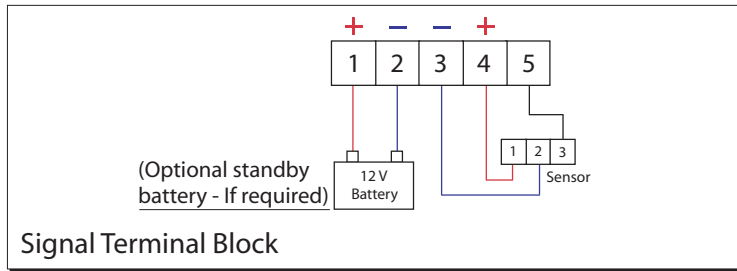
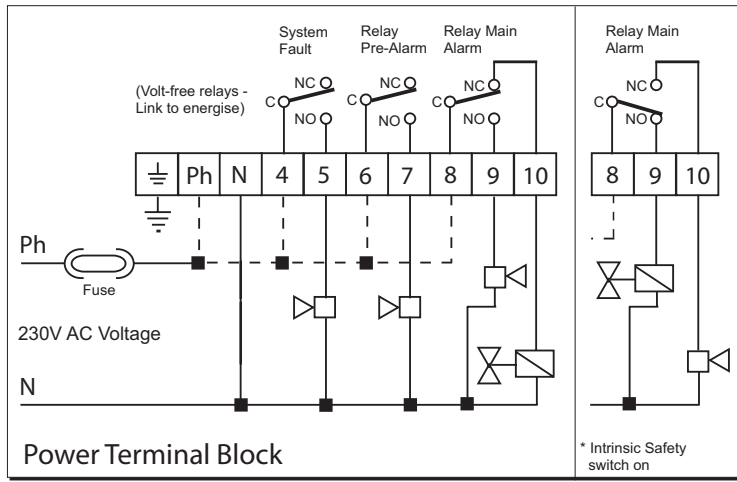

## Electrical Installation

The BX150 is a safety device designed to give audible alarms and automatically provide latched electrical isolation of associated gas safety shut off valves in the event of a gas leak or build up of toxic gases. The sensor can be located up to 100m from the gas detector. Cable size should be 1mm<sup>2</sup> CSA. If the sensor cables are run separately in specific conduit it is not essential to use screened cable but if the cables are routed through conduit or trunking containing other wiring the use of screened cable is advisable. The wiring should be performed by a qualified person in accordance with current regulations. The plug-in terminal rail makes installation easy and quick. Do not mount close to any heat source or in an area where moisture is likely to effect operation. The IP rating of this unit is IP44. Sensors should be positioned as shown below. If you require any guidance on this please call our technical help on 01905 797989.

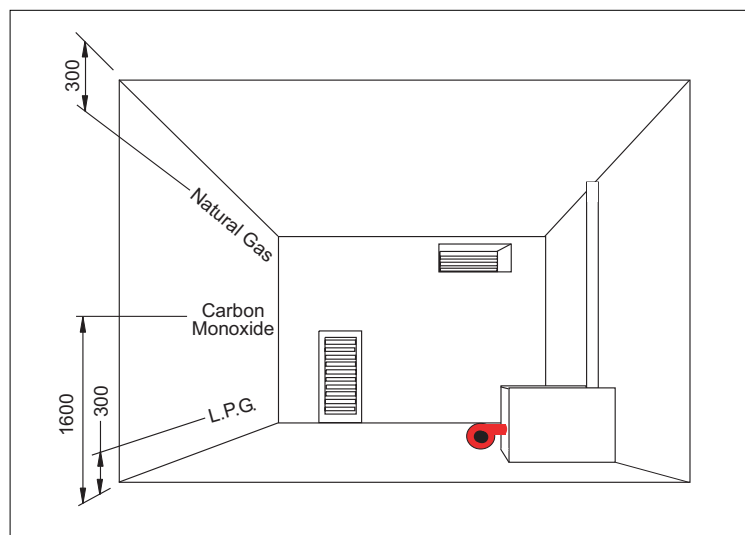

## Installing A Sensor

The sensors must be mounted as shown below with the sintered head pointing vertically down. When replacing sensors never separate a sensing head from its PCB. The sensor will have been calibrated using this particular board and therefore will not function correctly with any other.

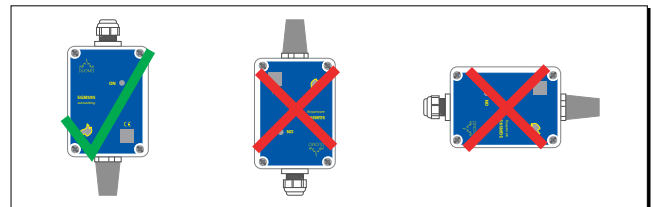

## Important Notes

**Always check the wiring before powering up the system.**

Do not test this sensor with anything other than Duomo test gas (see '**BX150 Operation**' section for further information). Concentrations above this will damage the sensor and shorten sensor life. The installation of this gas detector does not release the user from observing all the regulations concerning the characteristics, installation and the use of gas appliances; the ventilation of the environment and the elimination of combustion products in accordance with the local recommendations, regulations and bylaws. For any damage caused to people, property or animals resulting from incorrect connection, installation or application of this gas detector Duomo will not be held responsible or liable. To ensure correct function after installation Duomo provide a commissioning service using calibrated test gases. For this service call 01905 797989.

# Configuring The BX150

The BX150 has a DIP switch on the rear panel. Switch 1 is used to control the main alarm delay. Switch 2 is used to configure the main alarm latching mode. Switch 3 is used to select whether the unit detects toxic or explosive gases.

The BX150 can be configured to provide several modes of operation. The configurable parameters are:

## Switch 1 on the DIP switch

Intrinsic safety determines the condition of the main alarm relay and hence the operation of the gas valve. When it is 'ON' the relay is in a normally open state. When it is 'OFF' the relay is in a normally closed state. **NOTE:** This affects how the gas valve operates and means that you may need to change how it is wired to the BX150.

**Example shows Intrinsic Safety on**

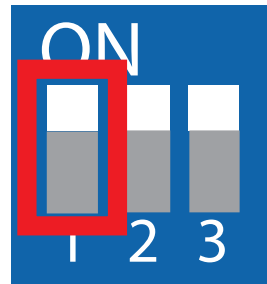

## Switch 2 on the DIP switch

Main alarm relay actuation method. This can be configured to provide either a latching or a temporary alarm operation. When the main alarm is actuated in an alarm condition if the switch is in the 'ON' position the relay will remain in this position even after the concentration of gas has reduced below the alarm threshold. If the switch is in the 'OFF' position the main alarm relay will actuate for 60 seconds and then if the level of gas has dropped will return to the volt-free main alarm relay to the running condition. The indication on the panel fascia and the audible alarm will still indicate main alarm. This mode of operation is used when using manual reset gas valves and battery back-up systems for extending standby battery life.

**Example shows detector configured for a latching main alarm**

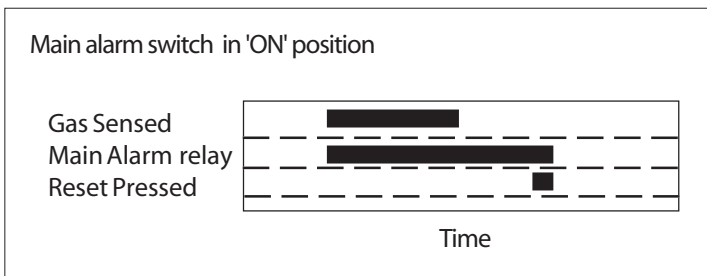
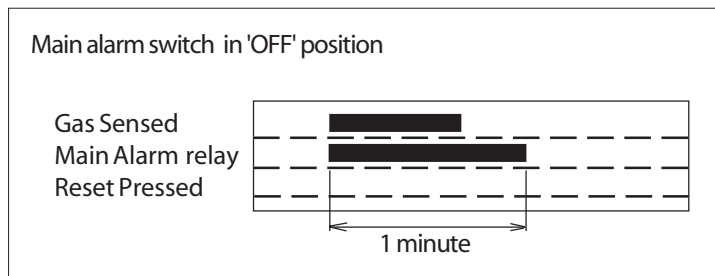
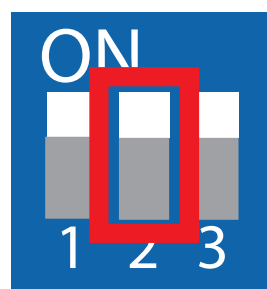

## Switch 3 on the DIP switch

Type of gas to be sensed. These are GAS or CO. The symbols on the front fascia of the detector are EN standard symbols and refer to any explosive or toxic gas. If toxic gas, e.g. carbon monoxide is to be sensed on a given zone move the switch to the OFF position. If explosive, e.g. natural gas, LPG, hydrogen etc. move the switch to the ON position.

**Example shows explosive gas setting**

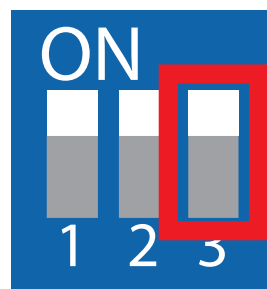

# BX150 Operation

Before powering up the BX150 once again check that all electrical connections are correct.

1. Apply power using the proper external switch. This switch should be fitted with protection fuses.
2. All of the lights on the fascia will light up in turn. This will take approximately 20 seconds. This checks the function of all the LED's.
3. The ON LED will remain flashing for about 90 seconds. This is the sensor warm-up period. The gas detector will not provide gas detection during this period. When the ON light becomes constant the detector is in operation.
4. By pushing and maintaining pressure on the manual TEST button a function test can be performed.

The sequence will be:

- a) The 8% LEL / 120ppm LED will be actuated.
- b) The 13% LEL / 200ppm and the pre-alarm LED will be actuated. The pre-alarm relay will be changed over and the buzzer will then issue a low frequency sound.
- c) The 20% LEL / 300ppm and main alarm LED will be actuated. In addition to keeping the pre-alarm relay switch on, the main alarm relay will be changed over. The alarm LED will light to show that the system is in alarm and the buzzer will issue a higher frequency sound.

By releasing the the manual TEST button the lights will go out and the audible alarm will cease. If a latched alarm function on the main relay is configured this will remain on until the RESET button is pressed.

5. In order to conduct a full function test it is essential to use Duomo or equivalent calibrated test gas. The maximum concentrations are;

- 40% LEL for methane in air
- 350ppm for carbon monoxide
- 0.85% (MOL) for propane

Any higher than this can reduce sensor life. NOTE: NEVER TEST USING NEAT GAS. THIS WILL POISON THE SENSOR.

6. To simulate a sensor fault situation disconnect the sensor plug. The detector will go into a FAULT alarm and the sensor fault relay will be actuated.

The control unit will then carry out the following:

- a) The FAULT and MAIN ALARM LED's will light up and blink
- b) The buzzer will issue a continuous sound
- c) The FAULT and MAIN ALARM relays will switch.

Reconnect the return cable and press RESET to restore the control unit functioning.

---

## Maintenance Procedure

This detector must be function checked as described above using calibrated test gas every 6 months. To arrange for a Duomo engineer to conduct this work or to arrange a service contract please call 01905 797989.

# Troubleshooting

The Problem	The Solution
The device does not start up	Check that the 230V mains power is correctly connected. If powered by the battery, check that the 12V DC power is correctly connected.
The FAULT LED lights up	Check that the connecting cables from the BX150 to the sensors are intact, that the sensors are properly powered and that the signal cable is correctly connected.
The OVERLOAD SENSOR LED lights up	Check that;  - the power polarity has not been inverted - that no short-circuit is present - that the probes were not damaged during installation, that no excessive current absorption is present
The OVERLOAD BATTERY LED lights up	Check that the connection cables are not shortcircuited, that the polarity has not been inverted and that the battery is not damaged.
The control unit is repeatedly issuing an alarm	Check that there are no gas leaks. If the alarm signal and the FAULT indicator light turn on together, check the sensor.
The control unit is issuing an alarm and does not shut off the devices connected to it	Check that the wiring is correct and that the DIP switch has been set properly. All relays must be free from electrical power. Check the drawing of the connections.
A 12V DC solenoid valve, which does not work well, is connected to the BX150	Direct connection of 12V DC solenoid valves or sirens to the BX150 is not permitted. An external power unit must always be used. The BX150 gives a maximum current of 50mA.

If you are experiencing difficulties, having made the checks listed above call Duomo on 01905 797989 for technical assistance.

## In case of alarm

- Extinguish any naked flames.
- Do not switch lights or electrical devices on or off.
- Open all windows and doors to increase ventilation.
- If the 'ALARM' LED is off the levels of gas have dropped. A responsible, qualified person is now safe to find the cause of the alarm.
- If the alarm sound remains constant, and the cause is not evident or possible to eliminate turn off the emergency isolation valves to the area and contact your gas provider emergency line. They will advice accordingly.

# Commissioning

It is strongly recommended that this detector should be commissioned by Duomo Commissioning Engineers or engineers approved by Duomo to carry out this work. A quotation for commissioning or service will be provided upon request. Fax site details and preferred date for commissioning to 01905 774296 and the Duomo Service Department will fax back confirmation.

The benefits of this equipment being commissioned by Duomo are:

On board spares. If for whatever reason this equipment doesn't function correctly Duomo engineers will have spares on board to ensure that the commissioning is successful.

A Duomo Commissioning Certificate is provided.

It is prudent to make electrical connection to the detector terminal plus when withdrawn and leave the plug off the detector so that the Duomo Engineer is the first to power up the unit on site. This allows wiring to be checked prior to commissioning and avoids damage due to incorrect connection. Guarantees for this product will become void if damage is caused by the installer.

---

## Technical Specification

Power Supply	230V AC 50Hz +/- 10%
Secondary Battery	12V DC +/- 10%
Power Consumption	9W maximum @ 230V / 2.5W maximum @ 12V
Relay contact range	10A resistive
Pre-alarm	13% LEL / 200ppm
Main alarm	20% LEL / 300ppm
Sensor fault	Short circuit, interruption, sensor deterioration
No. of remote sensors	1
Input signal	4 - 20mA
Device precision	1% FS
Microprocessor	8 bytes
Working temperature	-10 °C to 40 °C
Maximum distance for sensor connection	100m
Cable diameter for sensors	1mm <sup>2</sup> CSA
Dimensions	48mm x 96mm x 110mm
Protective rating	IP42

