



FP45 Current Monitor



- Digital display
- Monitors extract and/or supply fans
- Adjustable thresholds
- IP65 protective rating
- Insulation class II
- Conforms with EN50022
- Single, double, triple and quadruple models available
- 3 year guarantee

Application

The Duomo FP45 range of current monitors has been developed to monitor the current drawn by fan motors in ventilation systems. To comply with BS6173:2001 for commercial catering establishments it is necessary to prove that extract and supply air fans are operational before making gas available to the kitchen appliances.

The FP45 has two level switching points. Low - to prove that the fan is on. High - to ensure that the motor is drawing the expected load under normal conditions. For example, if the filters in a ventilation system become blocked, for whatever reason, the running current will increase higher than the normal running current. The FP45 is available in four different models; the FP45 Single, FP45 Double, FP45 Triple and FP45 Quad.

Features

FP45 Current Monitor relays monitor alternating or direct current.

Parameter setting makes it possible to select;

- Operating mode (overcurrent, undercurrent or current band)
- Type of signal (DC or AC)
- Release and hysteresis thresholds
- T1 and T2 delay type
- Fault storage activation

The FP45 includes LCD front display, two operation keys and a status indicator light.



CAUTION!

Carefully read the following instructions prior to installation of this device. Always keep this pamphlet for future reference. Ensure that the current monitoring system is wired correctly and is only used for the purpose for which it is intended.

Dimensions

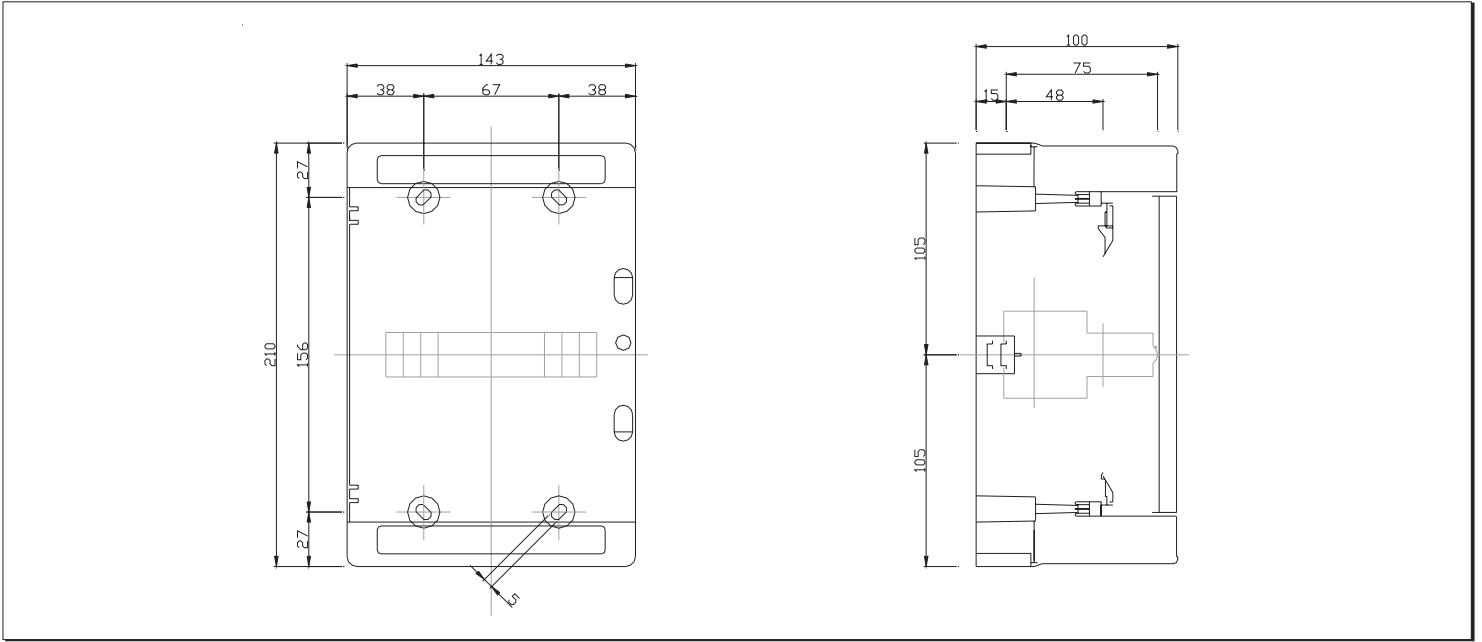

Wiring Diagram

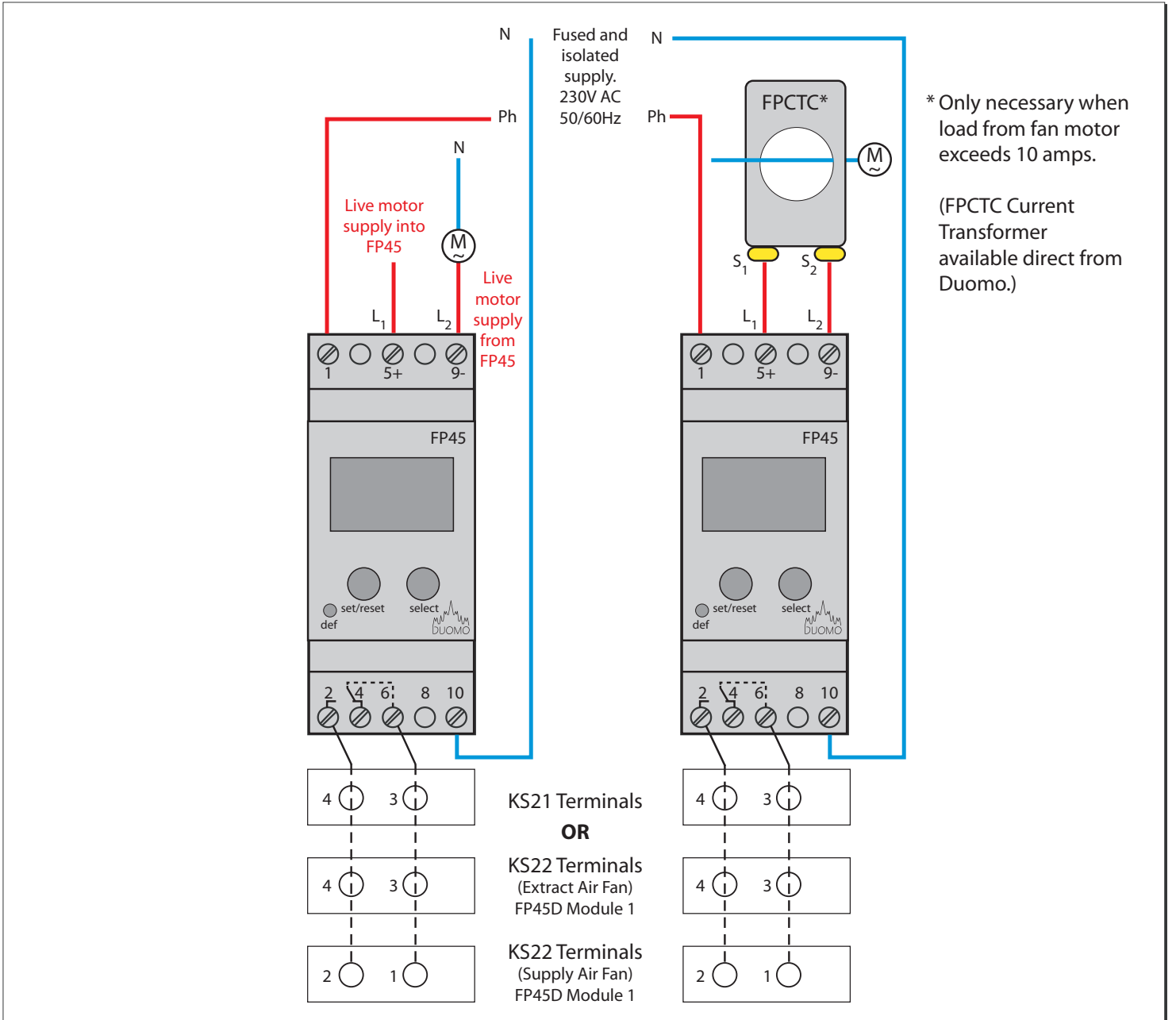

Program Setup Example

This example shows how to set up a current monitor to prove fan motor status. For this example we say that we have a motor with a running current of 5A.

1. Check that the running current of the motor is not above 10A. In this example the running current is 5A. If the running current of your motor is higher than 10A use a suitable current transformer and select the correct ratio in step 8.
2. Connect the system as shown with the motor supply passing through the terminals +5 and -9.
Note: These are not live and neutral connections. They are the live supply to the motor.
3. Check the wiring is correct.
4. Turn on the power to the FP45. Check the display with the motor feed turned off.
5. Turn on the motor. The running current will now be displayed e.g. 5A.
6. Enter the set up program by pressing and holding the set/reset and the select button simultaneously. The display will change to prog.
7. Set the current to AC by pressing set/reset.
8. Set the direct reading mode because the load is less than 10A. The display will show no. Press set/reset.
9. The FP45 will then display Up. Press select until UpLo is shown. Press set/reset.
10. The display will show Up Level and 0.0A. Set this value as the high limit with the motor in an over run or unusual load say 6.0A. This means that the FP45 will switch the relay from a run to a stop condition i.e. opening the circuit between terminals 2 and 6. Press set/reset when the correct value has been entered.
11. The display will change to Lo Level. This of course sets the low level threshold. Below this level the relay contacts are in the off position with the circuit open between terminals 2 and 6. For this example set the value to 4A.
12. Press set/reset to set t1 and t2. For fan proving applications t1 and t2 are set to 0.1 seconds.*
13. The next parameter sets whether the fault remains latched until manually reset. The function of the KS21 and KS22 Trio Safestart control panels ensure that this setting is not necessary. The fault is latched inside these units and requires manually resetting on the controller rather than on the FP45. Therefore select no by pressing set/reset.
14. The display will change to End. Press set/reset.

The FP45 will then display the running current of the motor and also close the contacts between terminals 2 and 6. This completes the FP45 set up and the unit should now be functioning correctly. Check the status of the relays both with the fan on and off to prove that the system is working correctly.

* t1 is the delay between a threshold actuation, Lo or Up, and the circuit between 2 and 6 being broken. t1 for fan proving operation is usually set to 0.1 seconds.

t2 is the start up delay. This will change the relay to the run condition on power up for the period set. Then change the relay over if the FP45 is calling for an under threshold (Lo) or over threshold (Up) alarm. This is usually set to 0 for fan proving applications.

Automatic Mode

In automatic mode, the display shows the measured current. If data storage is activated, pressing the reset key allows acknowledgement of faults. The **def** indicator light warns of faults. It will also flicker during the T1 time period and stays permanently lit if the fault is not removed.

Display Mode

Pressing the select key for one second allows you to select the display mode. Successive strokes of the select key make it possible to list the values of parameters (minimum and maximum) and display the current value measured during fault storage.

Programming Mode

Pressing the **set** and **select** keys simultaneously for 3 seconds allow you to enter the programming mode. Prog signal is displayed for one second when entering this mode.

Set key: Used to validate selection

Select key: Used to scroll through the various options.

Programming sequence is as follows:

1. Select type of signal, **AC** or **DC**.
2. Select direct measuring mode or current transformer.
3. Select monitoring operation mode. Overcurrent monitoring (**Up**), undercurrent (**Lo**) or band (**UpLo**). The usual setting for fan type operation is **UpLo**.
4. Select threshold;
High threshold if **Up** or **UpLo**.
Low threshold if **Lo** or **UpLo**.
5. Define hysteresis **Hys** (amps).
6. Select t1 seconds delay (seconds).
6. Select t2 seconds delay (seconds).
7. Select storage mode;
With storage, **Yes M**. This will latch the relay until the set/reset button is pressed.
Without storage, **No M**. The FP45 will auto reset. This is the usual setting for fan proving.
9. End

Confirm programming using the set key. Select key makes it possible to modify the various parameters (steps 1 to 8).

Technical Specifications

Electrical characteristics;

Supply: 230V 50/60Hz

Power consumption: <4A

Environment;

Operating temperature: -20°C to 55°C

Storage temperature: -40°C to 70°C

Functional characteristics;

Adjustable thresholds: 0.1 to 10A AC and DC

Measures: Direct - 0.1 to 10A~

Hysteresis: 5 to 50% of programmed threshold

Time delay when exceeding t1 threshold:

t1 = 0.1 to 12 seconds

t2 = 0.1 to 20 seconds

Connection capacity;

Flexible: 0.75 to 4mm²

Rigid: 1 to 6mm²

Enclosure;

Protective rating: IP65

Dimensions (L x H x D): 143 x 210 x 100mm

