

GS100M Gas Detector

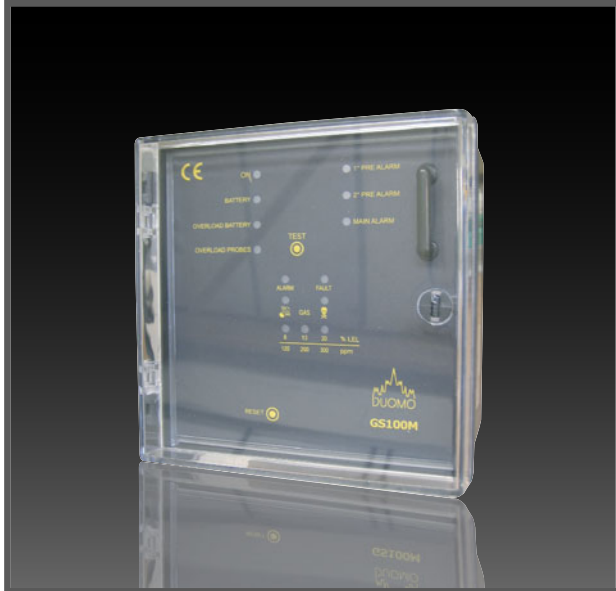

- Microprocessor control
- Wall or panel mounted
- 1 zone protection
- 4 - 20mA signal input
- Measuring range 0 - 20% LEL / 0 - 300ppm
- IP44 protective rating
- EN50194 for explosive gases
- EN50291 for toxic gases
- 3 year guarantee

Application

Duomo is recognised within the gas industry for providing a comprehensive range of low cost, high reliability gas detection for many applications. We have installed and commissioned natural gas and carbon monoxide sensors in applications such as boiler rooms, kitchens, car parks, aircraft hangers, factories and shopping centres. The GS100M is the command centre for the complete range of Duomo gas sensors. All Duomo products are manufactured to meet relevant European Normatives and proposals for explosive and toxic gases.

Operation

When the remote sensor detects the presence of the target gas a 4 - 20mA signal is sent to the detector, proportional to the level of gas. The GS100M then operates a pre-alarm relay - used for remote sirens or visual indicators. If the level of gas continues to rise then the second pre-alarm is actuated. In the case of explosive gases, when the level of gas reaches 20% LEL, the main alarm relay is activated to break the electrical supply to the gas safety shut-off valve (SSOV). The GS100M also has a separate volt-free sensor fault relay that actuates if the correct return signal is not sensed by the detector. The GS100M can be configured to detect explosive or toxic gases.

Features

The GS100M is a wall or panel mounted microprocessor based gas detector control unit. It can be configured to meet customer requirements. The following parameters can be changed using on board DIP switches:

- Sensor on/off
- Type of gas to be sensed (explosive or toxic)
- Intrinsically safe option (on or off)
- Main alarm relay action (latching or auto-reset)

The GS100M has two plug in terminal blocks. One is for the incoming mains supply and alarm circuit wiring and the second is for connecting the sensor wiring. This reduces the chance of incorrect site wiring. The front panel has two overload lights which indicate when a short circuit or an overload has occurred on the sensor wiring.



CAUTION!

Carefully read the following instructions prior to installation of this device. Always keep this pamphlet for future reference. Ensure that the gas detection system is wired correctly and is only used for the purpose for which it is intended.

Overall Dimensions

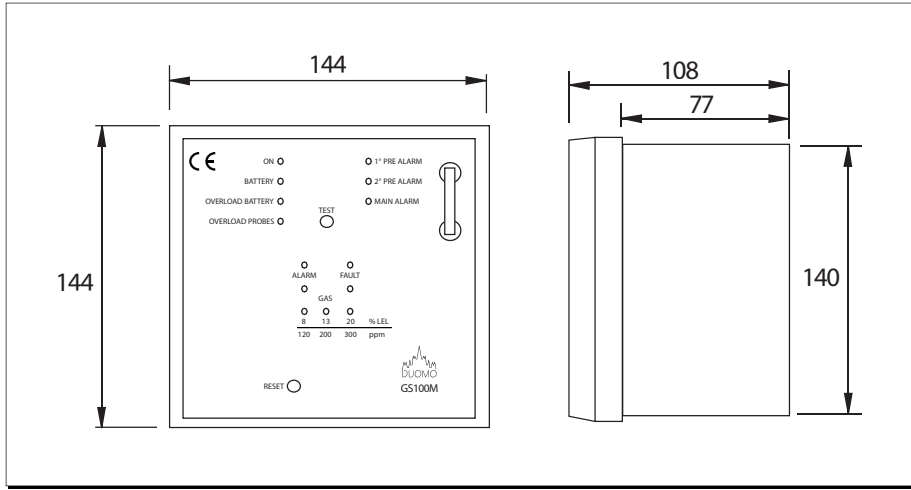

Cutout Dimensions

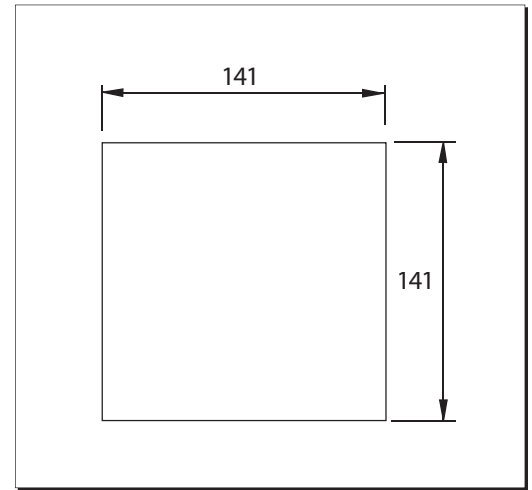

GS100M Fascia & PCB Layout

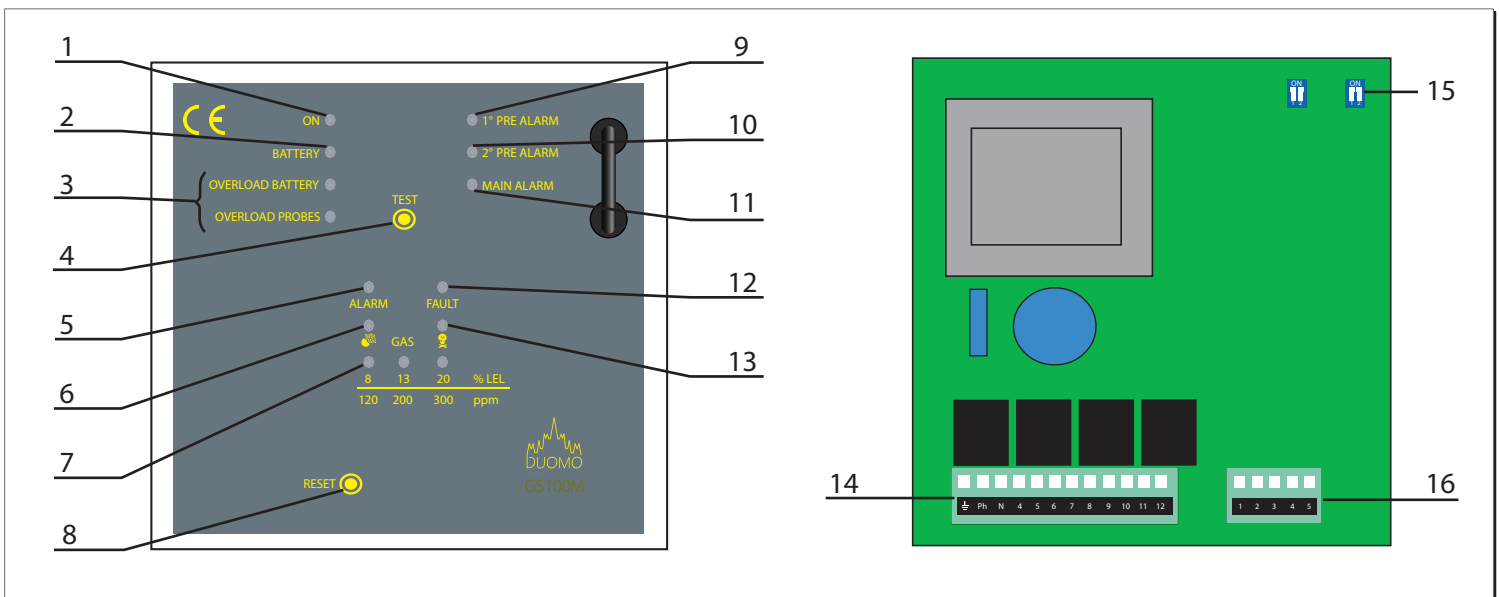

Key

- 1. Power On** - Lights when supply voltage is applied. This light flashes during self diagnostics start up.
- 2. Battery** - This lights when the GS100M is being powered by the standby battery. When this light flashes the standby battery has low charge.
- 3. Overload** - When lit indicates a short circuit or overload on the sensor circuitry.
- 4. Test** - When pressed checks the sequence and function of the GS100M.
- 5. Alarm** - Indicates an alarm status i.e. explosive or toxic gas has been detected.
- 6. Explosive** - This lights when the internal DIP switch for explosive gas is moved to the Gas position.
- 7. Pre-alarm LED's** - These lights indicate the level of gas sensed. 8 - 13 - 20% LEL and 120 - 200 - 300ppm.
- 8. Reset** - Press this to reset the detector after an alarm or sensor fault condition.
- 9. 1st Pre-Alarm** - 8% LEL concentration of gas detected. Pre-alarm relay 1 actuated.
- 10. 2nd Pre-Alarm** - 13% LEL concentration of gas detected. Pre-alarm relay 2 actuated.
- 11. Main Alarm** - 20% LEL concentration of gas detected. Main alarm relay actuated.
- 12. Fault** - Indicates a short circuit, sensor fault, loss of signal or incorrect connection of the sensor.
- 13. Toxic Gas** - This lights when the internal DIP switch for CO is moved to the CO position.
- 14. Mains and alarm relay wiring plug.**
- 15. Switches** - These are used to turn the sensor on/off, determine the type of gas to be sensed, to turn the intrinsically safe option on and off and alter the alarm actuation.
- 16. Sensor connection plug**

Fascia mounting the GS100M in a control panel

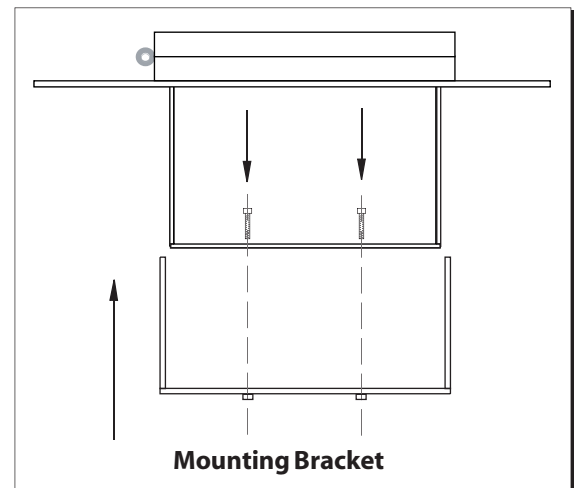

Typical Wiring Schematic for GS100M

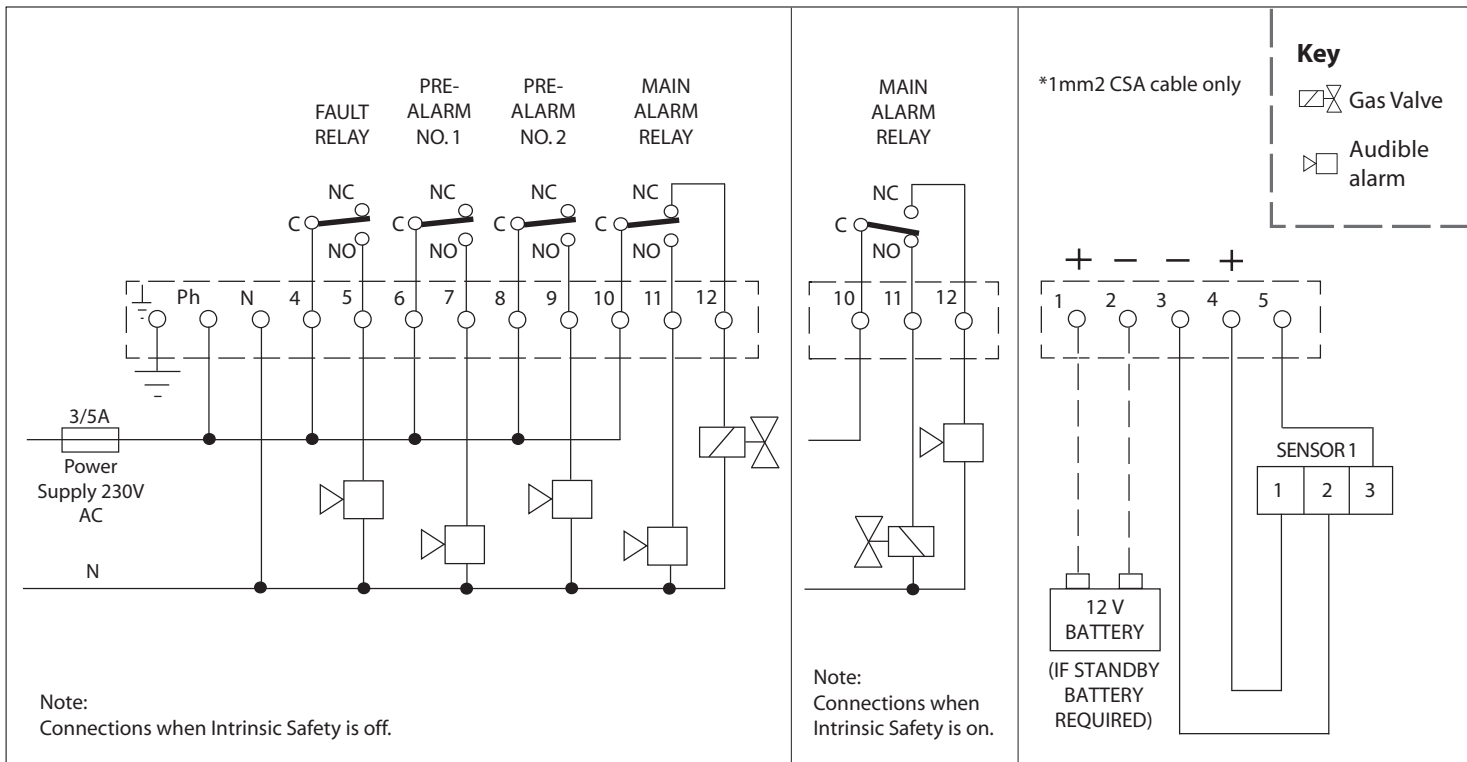

Electrical Installation

The GS100M is a safety device designed to give audible alarms and automatically provide latched electrical isolation of associated gas safety shut off valves in the event of a gas leak or build up of toxic gases. The sensor can be located up to 100m from the gas detector. Cable size should be 1mm² CSA. If the sensor cables are run separately in specific conduit it is not essential to use screened cable but if the cables are routed through conduit or trunking containing other wiring the use of screened cable is advisable. The wiring should be performed by a qualified person in accordance with current regulations. The plug-in terminal rail makes installation easy and quick. Do not mount close to any heat source or in an area where moisture is likely to effect operation. The IP rating of this unit is IP44. Sensors should be positioned as shown below. If you require any guidance on this please call our technical help on 01905 797989.

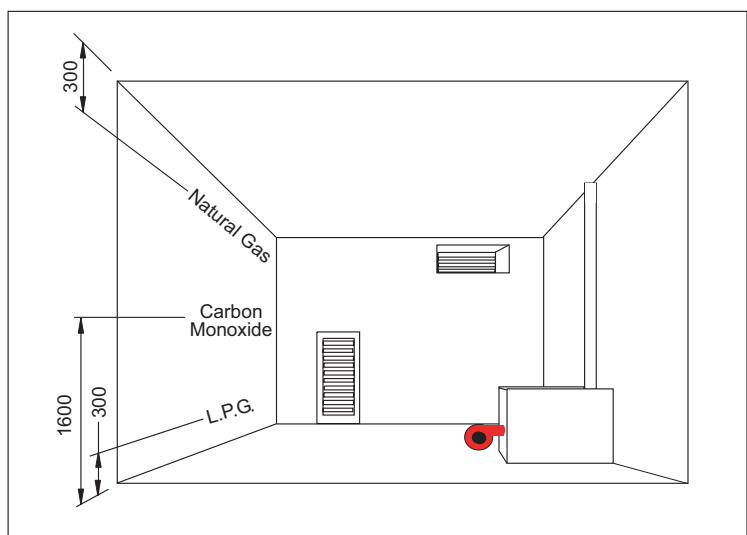

Installing A Sensor

The sensors must be mounted as shown below with the sintered head pointing vertically down. When replacing sensors never separate a sensing head from its PCB. The sensor will have been calibrated using this particular board and therefore will not function correctly with any other.

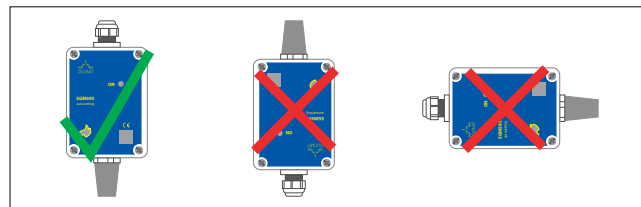

Important Notes

Always check the wiring before powering up the system.

Do not test this sensor with anything other than Duomo test gas (see '**GS100M Operation**' section for further information). Concentrations above this will damage the sensor and shorten sensor life. The installation of this gas detector does not release the user from observing all the regulations concerning the characteristics, installation and the use of gas appliances; the ventilation of the environment and the elimination of combustion products in accordance with the local recommendations, regulations and bylaws. For any damage caused to people, property or animals resulting from incorrect connection, installation or application of this gas detector Duomo will not be held responsible or liable. To ensure correct function after installation Duomo provide a commissioning service using calibrated test gases. For this service call 01905 797989.

Configuring The GS100M

The GS100M has two DIP switches on the PCB. The left switch is used to control the sensor connected to the system. The right switch is used to configure the controller itself.

The GS100M can be configured to provide several modes of operation. The configurable parameters are:

Switch 1 on 1st DIP switch

Zone ON or OFF - The GS100M will not look for a sensor on a given zone if the switch is moved to the OFF position. It is not necessary to remove the return cable from the sensor.

Example shows Sensor On

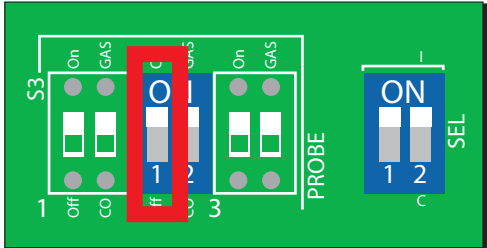

Switch 2 on 1st DIP switch

Type of gas to be sensed. These are labelled as GAS or CO. The symbols on the front fascia of the detector are EN standard symbols and refer to any explosive or toxic gas. If toxic gas, e.g. carbon monoxide is to be sensed on a given zone move the switch to the CO position. If explosive, e.g. natural gas, LPG, hydrogen etc. move the switch to the GAS position.

Example shows Explosive Gas Setting

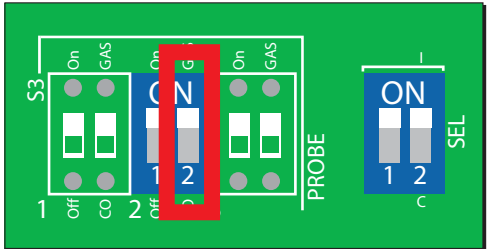

Switch 1 on 2nd DIP switch

Intrinsic safety determines the condition of the main alarm relay and hence the operation of the gas valve. When it is 'ON' the relay is in a normally open state. When it is 'OFF' the relay is in a normally closed state. **NOTE:** This affects how the gas valve operates and means that you may need to change how it is wired to the GS100M.

Example shows Intrinsic Safety on

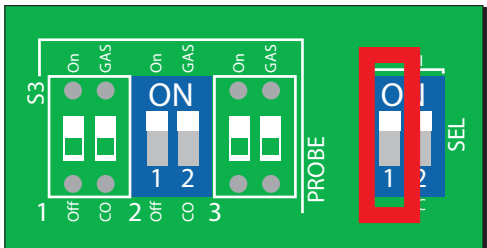

Switch 2 on 2nd DIP switch

Main Alarm relay actuation method. This can be configured to provide either a latching or a temporary alarm operation. When the main alarm is actuated in an alarm condition if the switch is in the 'C' position the relay will remain in this position even after the concentration of gas has reduced below the alarm threshold. If the switch is in the 'I' position the main alarm relay will actuate for 60 seconds and then if the level of gas has dropped will return to the volt-free main alarm relay to the running condition. The indication on the panel fascia and the audible alarm will still indicate main alarm. This mode of operation is used when using manual reset gas valves and battery back-up. systems for extending standby battery life.

Example shows detector configured for a latching main alarm

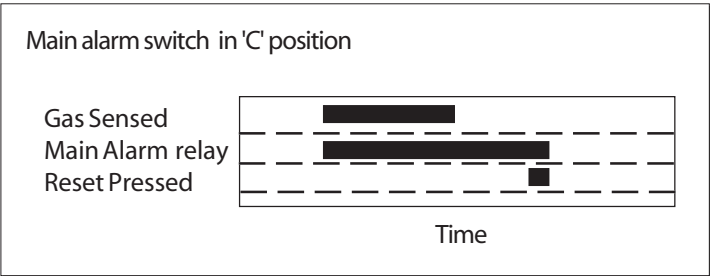
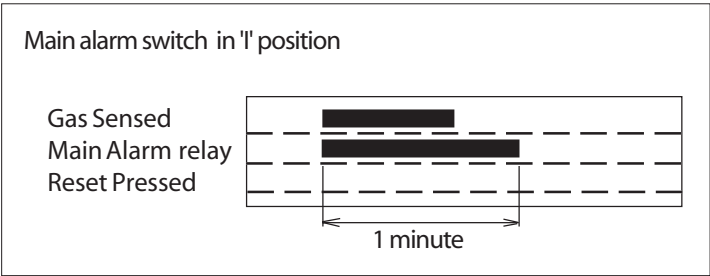
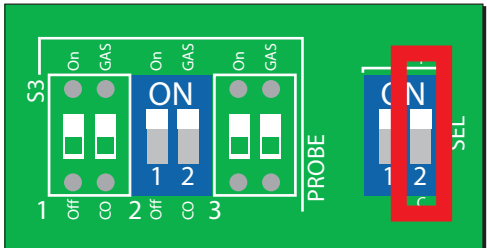

GS100M Operation

Before powering up the GS100M once again check that all electrical connections are correct.

1. Apply 230V supply to the Ph and N terminals. Ensure that the correct fuse is used in the supply. (3 or 5A max.)
2. All of the lights on the fascia will light up in turn. This will take approximately 20 seconds. This checks the function of all the LED's.
3. The ON LED will remain flashing for about 2 minutes. This is the sensor warm-up period. The gas detector will not provide gas detection during this period. When the ON light becomes constant the detector is in operation.
4. By pushing and maintaining pressure on the manual TEST button a function test can be performed for all pre-alarm relays and main alarm relay, together with LED's and audible alarm.

The sequence will be:

- a) The 8% LEL / 120ppm and Pre-Alarm no. 1 LED will be actuated. The Pre-Alarm relay no.1 will be changed over and terminals 6 and 7 will be connected and a low frequency audible alarm is sounded.
- b) The 13% LEL / 200ppm and Pre-Alarm no. 2 LED will be actuated. The Pre-Alarm relay no. 2 will be changed over and terminals 8 and 9 will be connected and the audible alarm will continue to sound.
- c) The 20% LEL / 300ppm and Main Alarm LED will be actuated. The Main Alarm relay will be changed over and terminals 10 and 11 will be connected, connection between terminals 10 and 12 will be broken and the audible alarm will continue to sound. (When 'Intrinsic Safety' is on, terminals 10 and 11 will be broken and 10 and 12 will be connected). The Alarm LED will light to show that the is in alarm.

By releasing the the manual TEST button the lights will go out and the audible alarm will cease. If a latched alarm function on the main relay is configured this will remain on until the RESET button is pressed.

5. In order to conduct a full function test it is essential to use Duomo or equivalent calibrated test gas. The maximum concentrations are;

- 40% LEL for methane in air
- 350ppm for carbon monoxide
- 0.85% (MOL) for propane

Any higher than this can reduce sensor life. NOTE: NEVER TEST USING NEAT GAS. THIS WILL POISON THE SENSOR.

6. To simulate a sensor fault situation disconnect the sensor plug. The detector will go into a FAULT alarm and the sensor fault relay will be actuated. This will close the contacts between terminals 4 and 5 and open the contacts between terminals 10 and 12 (Main Alarm relay). When the plug is reconnected the detector can be reset.

Maintenance Procedure

This detector must be function checked as described above using calibrated test gas every 6 months. To arrange for a Duomo engineer to conduct this work or to arrange a service contract please call 01905 797989.

Troubleshooting

The Problem	The Solution
No lights are illuminated on the fascia of the detector	Check that the electrical supply is reaching the device and that the plug in terminal rail is pushed into place.
One or all of the sensor fault lights are illuminated	Check that the plug is inserted correctly. Check that the sensor wiring is correctly terminated at both the sensor and detector. Check that 12V DC is present at the sensor. The green light on the sensor should be illuminated. Pressing the TEST button it is possible to check the efficiency of the device and if the sensors have been connected correctly.
Sensor fault continues to alarm	Check the sensor wiring. If the red Overload LED is lit a short circuit or overload has occurred on the sensor or the connecting cable.
The detector is subject to repeated alarms	Ensure that there is not an occasional gas leak. This may be due to a valve or joint which leaks under pressure.
The detector is in a main alarm condition and the main gas valve is not closing	Check that the connections are correct and that power is supplied to the valve i.e. the valve is not stuck in the open position. The function of the alarm relays both Pre-Alarm and Main Alarm can be checked by pressing the TEST button on the detector fascia. Check that the main alarm action is configured for a latching alarm (Switch 2 on 2nd DIP switch).
There is no supply to the solenoid valve	The Main Alarm relay is a volt-free contact, therefore you must connect the live supply to the common of the main alarm relay contacts terminal 10. A supply will then come from terminal 12 to the solenoid valve.
Sensor is connected, but no LED is lit on the front fascia	Check that the DIP switch is set to the ON position

If you are experiencing difficulties, having made the checks listed above call Duomo on 01905 797989 for technical assistance.

In Case Of Alarm

- Extinguish any naked flames.
- Do not switch lights or electrical devices on or off.
- Open all windows and doors to increase ventilation.
- If the audible alarm changes from continuous to intermittent the levels of gas have dropped. A responsible, qualified person is now safe to find the cause of the alarm.
- If the alarm sound remains constant, and the cause is not evident or possible to eliminate turn off the emergency isolation valves to the area and contact your gas provider emergency line. They will advise accordingly.

Commissioning

It is strongly recommended that this detector should be commissioned by Duomo Commissioning Engineers or engineers approved by Duomo to carry out this work. A quotation for commissioning or service will be provided upon request. Fax site details and preferred date for commissioning to 01905 774296 and the Duomo Service Department will fax back confirmation.

The benefits of this equipment being commissioned by Duomo are:

On board spares. If for whatever reason this equipment doesn't function correctly Duomo engineers will have spares on board to ensure that the commissioning is successful.

A Duomo Commissioning Certificate is provided.

It is prudent to make electrical connection to the detector terminal plus when withdrawn and leave the plug off the detector so that the Duomo Engineer is the first to power up the unit on site. This allows wiring to be checked prior to commissioning and avoids damage due to incorrect connection. Guarantees for this product will become void if damage is caused by the installer.

Technical Specification

Power Supply	230V AC 50Hz +/- 10%
Secondary Battery	12V DC +/- 10%
Power Consumption	11W maximum @ 13.8V
Relay contact range	10A resistive
Pre-alarm No.1	8% LEL / 120ppm
Pre-alarm No.2	13% LEL / 200ppm
General alarm	Fixed at 20% LEL / 300ppm
Sensor fault	Short circuit, interruption, sensor deterioration
No. of remote sensors	1
Input signal	4 - 20mA
Device precision	1% FS
Reaction time	<10 seconds
Microprocessor	8 bytes
Working temperature	-10 °C to 40 °C
Start-up self diagnostic delay	120 seconds
Suitable for use with sensor type	SG500, SG590, SGM595, CO100A, CO200A, SG810
Maximum distance for sensor connection	100m
Cable diameter for sensors	1mm ² CSA
Dimensions	144mm x 144mm x 110mm
Protective rating	IP44
Guarantee	3 years from date of manufacture

